

BROUAV

Quadrotor Agricultural Drone User Manual

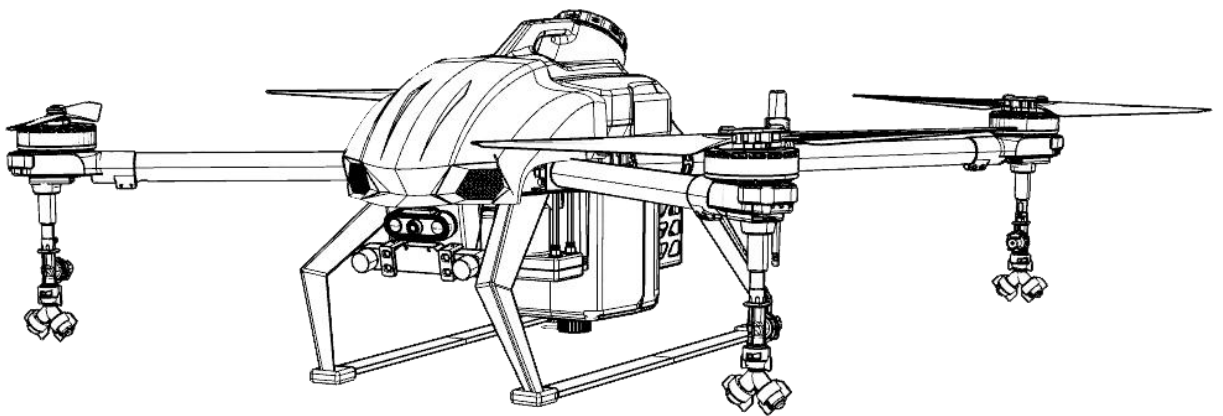

Qingdao Zhongfei Intelligent Technology Co.,Ltd

Table of Contents

Safety Summary.....	2
Product Description.....	9
Features.....	9
Function.....	9
Drone parts name.....	10
Product Operation.....	11
Flight mode.....	11
Unlock and lock.....	11
Operating mode.....	12
Drug-free alarm.....	16
Return.....	16
Low battery protection and low voltage protection.....	18
Indicator light.....	18
Remote Controller.....	20
Note.....	20
Overview.....	20
Structure and Presentation.....	21
Use and operation.....	22
Questions and Solutions.....	22
Maintenance.....	23
Transport and storage.....	23
Smart APP.....	24
Log in.....	24
App settings.....	37
Flight.....	39
Operating environment requirements.....	39
Flight restrictions and no-fly zones.....	39
Pre-flight inspection.....	40

Safety Summary

1. Be sure to calibrate the magnetic compass and compass before the first flight of the drone.

Calibration Method:

Calibrate the magnetic compass must rotate the drone clockwise, rotate the drone as the center, rotate around, and do not take the person as the center. Quickly flip the mode switch during calibration and see that the tail LED of the drone is long yellow. The UAV can be calibrated when the light is on. The mode switch must be placed in the middle GPS position after the switch is turned off. First, two people lift the drone during the calibration. Pay attention to the general height. Do not lift the high side and low side. It is not accurate to come out, rotate it clockwise after lifting, and then directly drop it in place when the LED light turns green, and then lift it directly. At this time, the head of the drone needs to be down, that is, the position of the tail LED light should be up. , Continue horizontally. Clockwise. Rotate around the drone, wait for the LED to change from green to fast flashing, indicating that the calibration is complete, just drop it in place, and unplug the power of the drone after the flashing light is over , You can turn on the drone and then power it on, even if the drone does not need to be placed in the correct position, you must turn off the power of the drone after the calibration is completed, and then power off the new drone. It can be done afterwards. For example, during calibration Resting time is too long, LED light turns red the calibration fails, then power must be energized to start calibration according to the above new method.

2. It is best to wait for the drone to complete its self-test each time before preparing to take off. After the self-test, only the green light flashes. The green light flashes once in manual mode, two times in GPS mode, and three times in autonomous mode.

3. For the models that need to be equipped with propellers, when installing the propellers, it is necessary to distinguish whether the propellers are anyway and whether the rotation direction of the propellers is consistent with the

motor rotation direction. (If the propeller is damaged, do not continue to use it, and replace it with a new one, to avoid the crash caused by the unbalance of the propeller)

4. Remember! Be sure to turn on the remote control first and then power on the drone when you are ready to fly. The remote control is first turned on and then turned off. When the flight is completed, first turn off the power of the drone and then turn off the remote control.

5. Check the power of the remote control every time you turn on the remote control. If you find that the power is insufficient, immediately replace the charged battery and prepare for the next operation.

6. If the battery is separated from the black and red wires when powering the drone, first connect the black wire and then the red wire when connecting to the drone, and then pull the red wire and then the black wire when pulling. If the battery of the yellow plug is connected to the drone, it must not be reversed. Distinguish the positive and negative poles. Insert half of the battery when it is powered, and then insert it to the end to prevent spark generation. If necessary, use the battery of the adapter to connect the adapter before connecting it to the drone.

7. When replacing the battery, first insert the BB sound to check the battery charge. Use two batteries at a time. Check whether the two batteries have the same power when replacing them. If the power difference is too large, do not use it. You must use two batteries with the same power to avoid a crash when flying because the battery power is too different. danger.

8. Pay attention to the flight status and battery power of the drone at any time when flying. If you find that the flight status is abnormal, immediately find a land and land. After checking, make sure that there is no problem before continuing the operation. (The power of the drone can be inserted into the BB ring or observe the LED lights at the rear of the drone. The LED lights flash alternately green and yellow to indicate that the battery is out of power. Disturbed. Be careful flying)

9. Take off. Be sure to stay away from the crowd when landing and flying, and keep a distance of 10 meters away from people. Pay attention to obstacles when flying. Observe and control the flight distance to avoid damage caused by collision. If there are interference obstacles such as high-voltage lines, telephone poles, high-voltage towers, etc., be sure to keep the distance. Pay attention to the flight status of the drone and adjust it immediately if there is any abnormality.

10. The signal of the remote control antenna is best placed horizontally. (It is better to be on the left side of the rear of the drone when flying, the signal reception of the drone is better)

11. When filling pesticide, a filter screen must be placed at the inlet of the tank to prevent debris or medicines that are not completely stirred evenly from clogging the spray head or water pump and affecting the working efficiency. (Be careful not to splash on the drone when filling pesticide)

12. Immediately after the end of daily operations, add buckets of clean water to the medicine bucket and spray them out by turning on the water pump to clean the remaining medicine liquid that is not discharged from the medicine bucket and the medicine tube to prevent blockage. It is best to remove the nozzle and the filter inside the nozzle to clean it separately. If the pump is found to be clogged, the pumping capacity becomes smaller, you can also remove it and clean it before using.

13. After the drone finishes spraying the medicine, the surface of the fuselage, landing gear, propeller, arm or medicine barrel may be splashed with liquid medicine or flying dust. Wipe clean with a towel or soft rag after the end of each day. Oxidation of the fuselage or other structural components will shorten the service life of the drone. (Do not wipe the cloth too wet)

14. The GPS needs to be placed at the forefront in accordance with the indicated arrow and cannot be skewed.

15. It is not possible to fly in rainy weather. (Thunder also interferes)

16. Pay attention to the water at the battery and battery interface, to prevent the danger caused by short circuit during use. (Be careful when placing the battery. Do not place the battery near an open flame, or where there is a heat source or damp or direct sunlight. Please ensure that the battery is stored in a dry and normal temperature environment. Ensure there is no flammability and explosion items around the battery when store. Ensure that the battery is not squeezed by any external force when storage and transportation)

17. If there are stains inside the battery plug or the battery connector on the drone, it is best to use a high degree of alcohol to clean it, to prevent the danger of melting at the connector due to high current during flight.

18. The new battery needs to be activated when it is used, and the charging current cannot be too high when the new battery is used for the first few times.

19. The battery must not be overcharged or over discharged when it is used. If the battery is damaged or damaged, it must not be used to avoid danger. When the battery is not used for a long time, it is best to charge and store it in a single piece of 3.85V power.

20. When charging the battery, use a special charger for charging, set the number of battery cells of the battery pack (charging voltage) accurately, you must carefully observe the display of the charger in the first few minutes of charging, the battery of the battery pack will be displayed on the top The number or voltage, if you are not clear, you should not charge or use the charger you are familiar with.

21. Do not charge when no one is watching, to avoid potential safety hazards such as fire or explosion due to lithium battery charging.

22. Don't puncture the battery. If the battery is bulging, there is a safety hazard. Especially when charging, it should be stopped immediately and the battery should be moved to a safe place.

23. Avoid battery impact, internal short circuit may be caused after the impact,

there will be hidden safety hazards (there is a precedent before)

24. When charging, charge in a well-ventilated and open place. If the battery bursts, thick smoke and melted material will be sprayed out. Prepare a bucket of sand. When you fly or recharge, if the battery catches fire, fire extinguishing is very effective and necessary.

25. When the temperature is low, the power of all lithium batteries will be significantly reduced, and the battery life will be shortened. Because the activity of lithium ions is reduced in winter, the battery power is definitely not as long as the battery life in summer.

26. If the UAV is equipped with a ground station, the ground station antenna at the end of the UAV cannot be removed when the ground station is not used. (It is recommended not to use the ground station as much as possible, the probability of using the ground station to fall will increase)

27. There must not be any obstruction between the drone and the remote control during the operation. For example, if the sprayed crops are high, the drone operator must stand at a high point. During the flight operation, the operator must be able to see the drone, observe the flight status, remember not to fly blindly. (If there is obstruction between the drone and the remote control or the flying distance is too far, the remote control signal will be affected, which will also affect the stability of the drone)

28. The flying height must not be too low during the operation, the spraying effect may not be good, and also prevent the unevenness of the crops. If the flying height is too low, it may cause damage to the drone and the crops.

29. To switch modes during flight, the joystick must be in the neutral position.

30. When using the AB point mode, if you want to stop the operation or get back the manual control right after the operation, you need to slide the mode joystick from the autonomous mode to the GPS mode. (When clearing the AB point, the drone must be landed on the ground and then cleared. It cannot be

cleared directly in the air. After clearing the AB point, the joystick of the AB point must be placed in the neutral position.)

31. Check whether the blades of the folding paddle are loose before flying. The blades should have the same tightness, not too loose or too tight.

32. After the flight is over or the drone is dropped, immediately use the remote control to lock the motor. Prevent the motor from driving the propeller to continue to rotate. (The two joysticks on the remote controller listed below is used to start and stop the motors)



33. After each day's work, check the fuselage, arms, folds, propellers, GPS, motors, etc, to make sure all are in good condition. Check carefully to make sure that all the screws are fixed well.

34. **Battery power**

Be careful not to hover without spraying when flying with full load. If you need to hover without spraying, add less liquid. Do pay attention to the battery level.

35. **Fruit tree homework**

When spraying for fruit trees, be sure to stand on the roof of the car and keep same level with the top of fruit trees. So as not to cause signal blind zone due to the angle.

36. **Plot boundary**

When taking off, landing, changing lines, be sure not to get too close to the boundary of plot. Because the drone is large, the spray width is wide, the braking distance is longer. A safety distance of 10 meters must be kept from the boundary. Don't worry about the crops at boundary can't be sprayed, it's no problem for the heavy payload drone.

37. **Dot and calibrate**

When dotting, drone calibration, must not be in the area of high-voltage lines,

transformers, houses, or under trees. Otherwise, the signal is not good, may cause deviation.

Important note: When using the handheld mapping device (RTK version of the remote control) to do dots, the drone must be powered off. Do not power on the drone, otherwise the RTK mode cannot be used to collect points, which will result in inaccurate point collection.

38. **Battery connection**

For the plugs of drone and battery, these two connection parts must be kept clean. Frequently clean with high grade alcohol. Don't have dirty things.

39. **GPS/screw**

Before flying, be sure to check the GPS seat by hand to see if it is loose. There must be no looseness, otherwise the drone will not fly in right direction.

After flying for two days, the screws of the whole drone should be tightened once.

40. If the drone uses two batteries to fly at the same time, pay attention that the batteries are used and charged at the same time to ensure that the voltages of the two batteries are close when flying, to avoid the situation that one battery is powered and the other is out of power, otherwise the drone will land on the basis of the battery with the lowest voltage.

42. Operate strictly in accordance with the instructions.

Product Description

Features

1. The fuselage adopts a closed design, which can prevent pesticides from entering the flight control system and provide safety guarantee for long-term operation;
2. The plant protection machine has built-in GPS and compass module, with fixed-height and fixed-point flight function, which can well maintain the spray height and spray route accuracy of the operation;
3. The height limit and flight speed limit of spraying operation can be set. The high-pressure spraying system has good c effect. Under the wind pressure of the aircraft, the drug mist has the characteristics of strong penetration. Leaf face.
4. Modular design of functional components, easy maintenance and upgrade.
5. Using intelligent plug-in battery
6. Use quick-plug medicine barrel
7. High-pressure brushless water pump is adopted, and the ESC is fully waterproof.
8. Wear the case, optimize the whole machine, and hide the medicine circuit.
9. 7075 aviation aluminum (high grade) is used for the folding part.
10. Alternating spraying function, the spray head can be switched independently.
11. The arm can be quickly disassembled.

Function

1. Automatic line-feeding spray (recyclable spraying);
2. Automatic flight spraying at point AB
(plant protection aircraft can fly autonomously and record automatically after spraying);
3. Fully autonomous spraying of (the area and terrain of the selected plots of the ground station are plots determined, and the aircraft can be autonomously sprayed);

4. One-click record of medicine break point (automatically record the main point after pesticide spraying in the spraying process and return to take-off point to change medicine);
5. One-click return to the medicine break point (after spraying pesticides, the main points are automatically recorded after spraying, and then return to the take-off point to change the coloring medicine. After changing the medicine, the machine will automatically return to the medicine break-off point. spray);
6. Low voltage automatic return home (automatically record the power failure point during the spraying process and then return to the take-off point to replace the battery. After replacing the battery, the battery will automatically return to the drug-off point. The aircraft will not be sprayed without arriving at the location to avoid repeated spraying);
7. Attitude operation mode, GPS operation mode (in the case of improper operation, let go regardless, the aircraft can automatically return to the take-off point and the fixed point in the sky will not cause a crash and an accident);
8. Radar wave anti-terrain height setting operation (according to different plots, after the crop distance and spray height are set, the spraying process can automatically adjust the height of the aircraft and crops according to different terrain changes);

Drone parts:

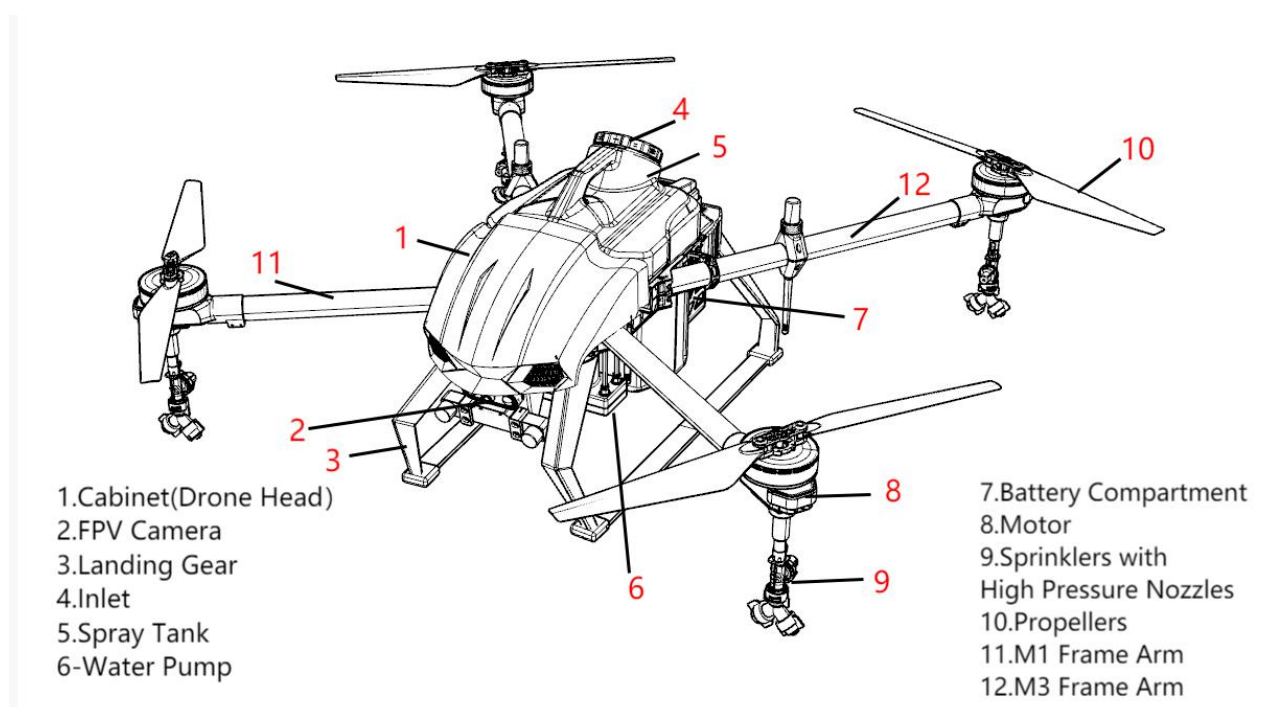

Product Operation

Flight mode

Flight control mode	Control method	Characteristic	Remarks
Highly maintained mode	Manual control	When the joystick returns to center, the aircraft maintains its attitude autonomously, and the throttle position can be set at a high level, but it cannot achieve precise fixed-point hovering and needs to be corrected manually.	
Position retention mode	Manual control	When the satellite signal is good, it can hover at a fixed point with high precision and achieve speed limit	
Fully autonomic mode/AB point mode	Automatic	Automatic/semi-automatic flight according to the mission route/AB point set by the ground station. It's Dependent on satellite.	The throttle can still control the height, and the center of the throttle will maintain the current height

Unlock and lock

Unlockable mode: Highly maintained/Position retention mode

Lockable mode: Highly maintained/Position retention mode

Automatic locking

- a. In any flight mode, after unlocking, the aircraft does not take off, the throttle is the lowest, and no operation within 3s, the motor will automatically lock;
- b. In addition to the attitude-stabilization mode, all flight modes have an

automatic landing recognition function that automatically controls stalling;

c. Except for the attitude-stabilization mode, the throttle will not be stopped if the throttle is pulled to the minimum during flight.

Operating mode

General AB point mode

In order to meet the user's demand for the small area shape and regular plot operation, the autonomous spraying function can still be used, and at the same time effectively reduce the user's operating intensity, the BROUAV system has a very practical "AB point mode", which is to control the aircraft to execute the L shape The route, that is, one spray route after each line change and line change is a "route unit". This operation mode can not only meet the requirements of rapid operation, but also ensure the uniformity of spray.

Preparation for takeoff: All channels of the remote control are set to the low position, the medicine box is filled with liquid medicine to control the aircraft to take off;

Record preparation: control the aircraft to fly to the point A position and switch to "position maintaining mode" or "GNSS assist mode";

1. Record point A:

The remote control 8 channel is set to high position, record point A, after success, the flight indicator flashes blue and white alternately 4 times, the ground station has "A"Point" record, manually turn on the pump;

2. Record point B:

The remote control 8 channel is set to the low position, record point B, after success, the flight indicator flashes green and white alternately 4 times, the ground station has a "point B" logo record, manually turn off the water pump;

3. AB point mode:

AB point planning is successful, the mode channel is switched to autonomous mode, and the distance from the current position to point A or point B is less

than 100 meters, the aircraft will execute AB point mode and fly to point A or B closest to the current position Click and hover, wait for the front and back fine-tuning or line-feeding instructions, and the aircraft enters the operation preparation;

4. Start the operation:

according to the needs of the operation, turn the rocker to the left / right and hold it for more than 1 second, then return to the center, the aircraft will wrap in the corresponding direction and fly in the direction parallel to the AB line, and the water pump will start automatically;

The line feed command takes effect only when manual line feed is enabled and manual obstacle avoidance is not enabled.

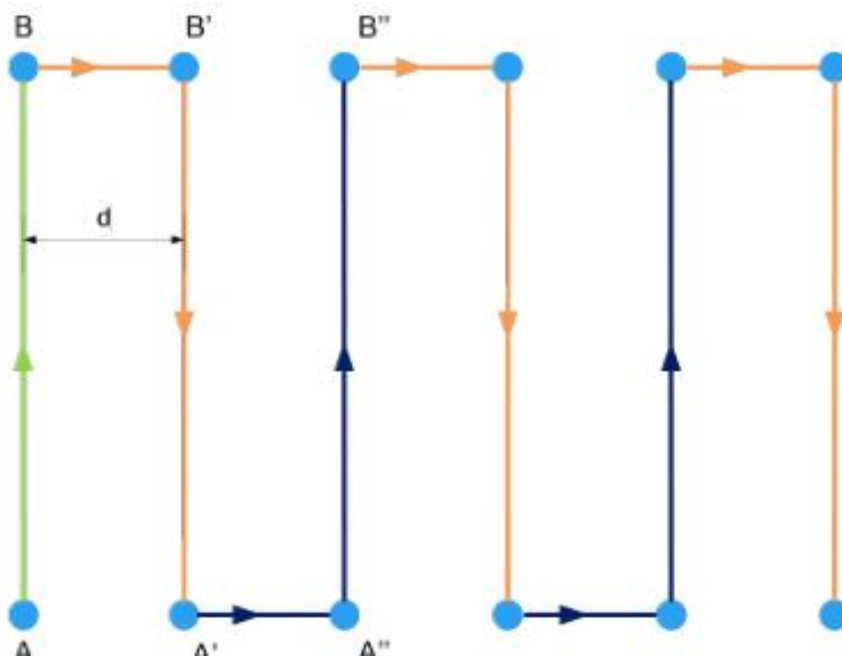

5. Line-breaking operation:

Toggle the joystick during the flight at point AB and hold it for 1 second. After the aircraft reaches the next point of the spray route, it will directly switch to the next point according to the direction of the joystick and fly to the next point; if the horizontal switch is not turned during the flight Rolling the channel, the aircraft will hover and wait for the line feed command after reaching the end of a single spraying route. After issuing the line feed command through the roll lever, the aircraft will continue to perform the spray task;

6. Position adjustment:

In order to meet the spraying needs of non-parallel land parcels and improve the adaptability of the AB point mode, BROUAV provides a position adjustment function. After the aircraft executes a single L-shaped route and hovers, it will move the pitch stick forward / back and hold it for more than 1 second, then return to the center, and then move the roll stick to the left / right. The starting point position of the next line will be adjusted according to the tilt direction of the tilt rocker.

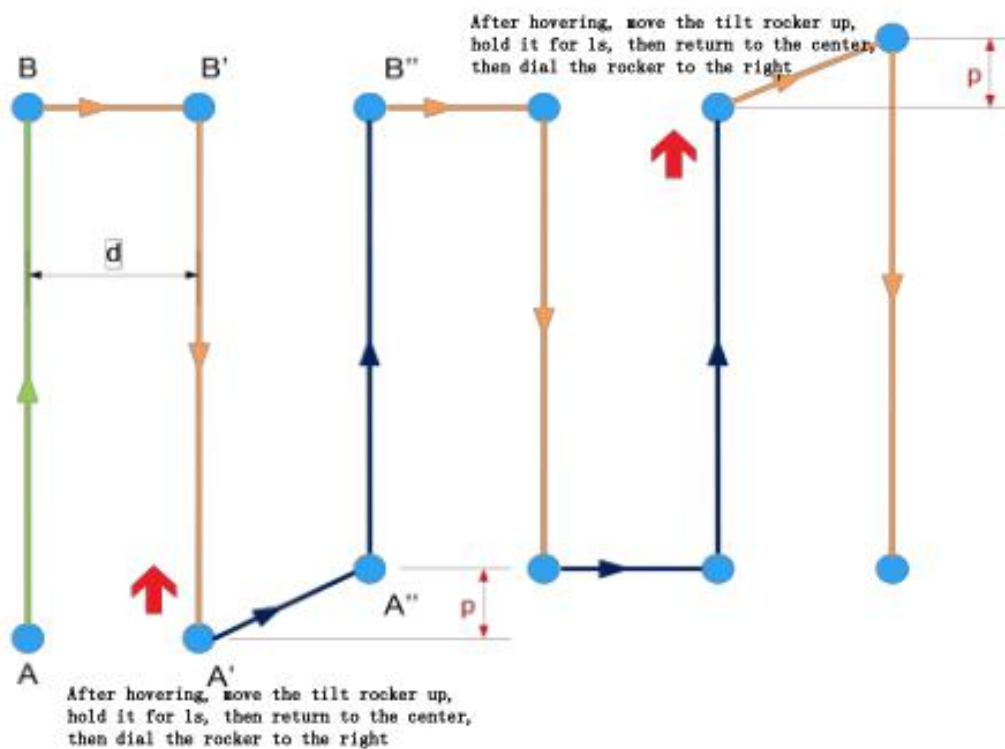

7. Breakpoint continued spraying:

If there is no medicine in the flight (detection is turned on), the battery voltage is low (detection is turned on), trigger the remote controller out of control protection, etc., the breakpoint will be automatically added and returned to the flight. Point and return

Note: The function of recording the medicine break point must be unlocked to effectively record; when the pump is turned on and off again, the last medicine break point recorded will be overwritten automatically.

8. AB point clearing:

It is recommended to perform a clearing action every time before hitting AB point or after the operation is completed. When the aircraft is landing and locked, the 8 channels of the remote control are quickly dialed back and forth twice according to "low position → high position → low position". If the clear is successful, the indicator light flashes red and blue alternately 4 times;

9. Overwrite record of AB point:

When the AB point record is wrong or the AB point needs to be re-recorded, the user does not need to clear the AB point in the locked state and then take off and restart the dot, but directly re-record the points A and B on the original basis. Operation, the new points A and B will overwrite the original points A and B.

Manual AB point mode

The manual AB point operation method is more flexible than the automatic AB point, which greatly enhances the adaptability of irregular small plots in plant protection operations, but the entire process requires far more manual operations than automatic AB points.

1. The operation mode of manual AB point and automatic AB point is the same. After entering autonomy, you need to change the line through the roll operation, and fly forward and backward through the pitch operation, but the flight process is controlled by the pilot except that the heading will be automatically maintained:
The flight speed is determined according to the pitch of the remote control, but it will not exceed the upper limit of the set speed;
The line-breaking motion is determined by the timing of the flying pilot's roll, provided that the aircraft needs to be carried out at a speed of less than 1m / s;
2. The breakpoint function and generation method of manual AB point and automatic AB point are consistent;

3. The method of clearing the manual AB point is the same as the automatic AB point.

4. The default setting is automatic AB point

Only one of automatic AB point and manual AB point can be selected. Please confirm the operation method of using AB point in the system settings—agricultural settings—AB point before the flight.

5. AB point distance correction

When flying from point A to point B, push up the pitch stick, then point B will be extended 1 meter forward; Pull the pitch stick down to shorten point B by 1 meter;

When flying from point B to point A, push the pitch stick upward to shorten point A by 1 meter; Pull down the pitch stick, then extend point A 1 meter back.

Drug-free alarm

Dosage testing

The dose detection function will only be triggered in the AB point or fully autonomous mode. The dose detection action: select "Home or Hover". After the AB point mode or fully autonomous mode has no medicine, it will record the breakpoint and return to the flight or hover. Stop and execute the action can be confirmed again by "Execute Action Setting".

Return

Return flight: Return flight is one of the important protection methods for safe flight. The return flight process is: after the aircraft climbs 2 meters at the current position (which can be modified by default), level flight to a safe point and hover to wait for operation.

Auto home mode

The auto-return mode provides safety guarantee for long-distance flight and runaway protection.

1. Working conditions

After the star search is completed and the positioning accuracy meets the requirements (LED red light does not flash or red light flashes once), each time the user unlocks, the flight controller will automatically record the current position as the home point. After entering auto home mode, the green LED flashes quickly.

2. Operating instructions

The auto-return mode can be triggered by the joystick or by the runaway protection. When the remote control CH6 mode switch is set to the one-key home position or the flight control enters the out-of-control protection, if the aircraft is more than 2 meters away from the home point, the aircraft will automatically rise to the set altitude (if the current altitude is greater than the set home altitude, then Return at the current altitude). During the return, the aircraft will not accept manual intervention of the joystick channel. After the aircraft reaches the home point, it will first hover in the air for about 3 seconds, and then it will slowly land. At this time, the flight status of the aircraft can be controlled by the remote control lever (but the throttle lever does not work), which is convenient for the aircraft to find a more suitable landing point. The aircraft will automatically lock until the aircraft has completely landed. If the distance between the aircraft and the home point is less than 2 meters, the aircraft will land on the spot and automatically lock.

Precautions:

- 1. The premise of automatic return to home is that the return point of the aircraft has been recorded. If you need to use automatic return to home, please unlock it after the GPS star search is completed. Please refer to the appendix LED tri color lights to indicate the status and significance.**
- 2. When the aircraft is very close to people, it is recommended not to switch to auto return mode to avoid accidents.**

Low battery protection and low voltage protection

BROUAV provides a voltage protection function based on a correctable voltage value, that is, the user can correct the voltage value measured by the flight control through the ground station (if the actual value and the measured value are different, this function can be used to correct the measured value), the flight control detects a single chip Voltage and implement protection.

When the flight control detects that the battery voltage reaches the level 1 alarm voltage, the flight control LED light flashes yellow three times.

When the detection voltage reaches the second level alarm voltage, the yellow light flashes quickly, and the aircraft's power is about to run out.

Indicator light

Serial number	RGB status	Fault state	Explanation
1	light is not on	Light malfunction or updating log	
2	Any color lights are always on, and the ground station cannot be connected	System halted	

3	Red/white lights alternately flash	Flight control initialization	
4	Red/yellow/blue/green flash alternately (low brightness)	The device is not calibrated	Remote control, compass, accelerometer
5	Red/blue/green flashes alternately	Equipment calibration or testing	Motor test, ESC calibration
6	Single yellow flash	Remote controller malfunction, Low voltage primary protection, pesticide running up protection	
7	Yellow light flashes quickly	Low voltage secondary protection	The action is forced landing
8	Purple single flash	Magnetic compass failure	
9	Purple double flash	Accelerometer malfunction	
10	Purple light flashes quickly	Other failures before unlocking	Or initialization finished is not
11	Steady red	Log storage device malfunction	
12	Red/yellow flashes alternately	GPS malfunction	
13	Blue light single flash	No GPS, no unlock	Blue light indicates no fault
14	Blue light is always on	No GPS, unlock	
15	Green single flash	With GPS, not unlocked	Green light indicates no fault
16	Green light always on	With GPS, unlock	
17	Flashing green	GPS high accuracy positioning	

Remote Controller

Note

This product uses the following terms to classify the potential hazards that may be caused by improper operation.

Note: If you do not follow the instructions, it may cause property damage and minor injuries.

Note: If you do not follow the instructions, it may cause property damage, major accidents and serious injuries.

Warning: After reading the entire user manual, familiarize yourself with the functions of the product before proceeding. If the product is not operated correctly, it may cause serious injury to yourself or others, or cause product damage and property loss. This product is relatively complicated, it takes a period of familiarity before it can be used safely, and it needs to have some basic common sense before it can be operated. If there is no strong safety awareness, improper operation may lead to product damage and property loss, or even damage to itself or Others cause serious injury. This product is not suitable for children. Do not use parts that are not provided or recommended by Brouav, and must strictly follow Brouav's guidelines to use the product.

Overview

Product Features

The H12 series uses Qualcomm 625 processor, equipped with Android embedded system, adopts advanced SDR technology , and super protocol stack, so that the image is clearer, the delay is lower, the distance is longer, and the anti-interference is stronger, whether it is a drone , Robots, industrial control equipment, etc. can be applied.

Structure and Presentation

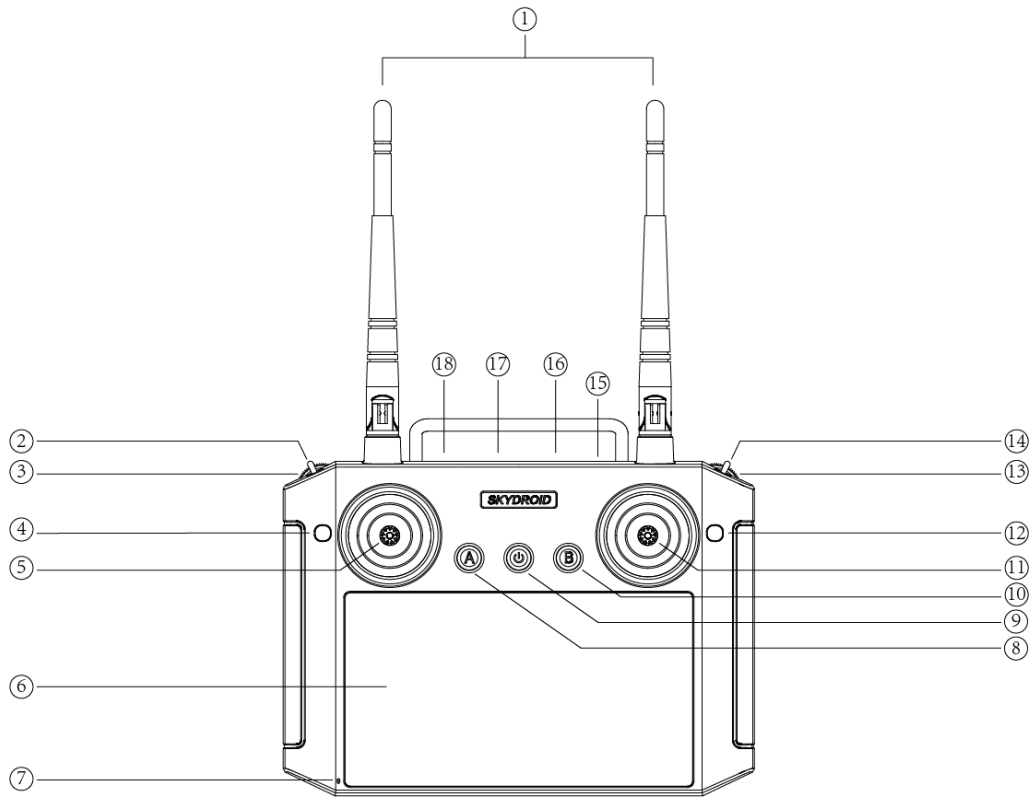

Serial number	Annotation	Serial number	Annotation
1	2.4G 3dB antenna	10	AB mode
2	Highly maintained mode(left) - Position retention mode(middle)- autonomic mode(right)	11	Joystick X2 (left and right), Y2 (front and rear)
3	Dial G	12	Turntable
4	Button C	13	Wheel H
5	Joystick X1 (rotation), Y1 (lift)	14	Water pump
6	5.5 inch screen	15	speaker
7	MIC port	16	SIM card slot
8	Return home	17	Charging port
9	Switch	18	PPM output

Remark: No. 2: Position retention mode: could use AB point mode; could set the speed

1. Working conditions

Power supply mode and Precautions

The H12 series ground terminal has a built-in integrated rechargeable lithium battery, compatible with the market standard Micro USB interface, and a 5V power adapter (such as a USB charger for digital products such as mobile phones and cameras) for charging.

If you encounter smoke, peculiar smell, or night leakage when charging at the ground end, please do not continue to charge the ground end, please send it to our company for repair.

Do not charge the product in the area where babies touch, to avoid the risk of electric shock. Do not charge this product in an environment exceeding 60 ° C .

2. Safety warning

Beginners please pay special attention to the following safety precautions! Please read carefully !

It is forbidden to fly when fatigue, drunk and other physical conditions are not good!

It is forbidden to fly in bad weather such as rain or strong wind!

It is forbidden to fly near high-voltage lines, communication base stations, places where people gather or move!

It is forbidden to fly in airports and other places where flying is prohibited!

It is forbidden to control the flight model in crowded places, parking areas, or other areas that may cause property damage or personal injury. Before flying, do a good job of equipment testing of the aircraft, and check whether the transceiver system and the aircraft are normal;

Please use a guaranteed professional charger to charge the battery.

The antenna of this product is a fragile part to avoid damage due to excessive force.

Questions and Solutions

1. Is other APP can be installed?

The permissions of the remote control are all open, and there is no special software and no restrictions on the installation and uninstallation of software.

2. Data transmission can not be connected?

Check whether the ground station has been installed correctly and whether the baud rate is the flight controller's adaptive baud rate. Check RX the TX if the reverse (right connection RX contact the TX the TX connection RX).

3. The remote controller has been ringing

When the remote controller is not successfully connected with the receiver, the remote controller will always give a prompt alarm.

4. Ground station sound is too low to hear

You can find the sound options in the settings, and adjust the sound in the sound settings.

5. What's other function of the TYPE-C port besides charge.

In addition to charging, the TYPE-C port can also be connected to a computer for file viewing and screen projection.

6. A remote controller connected to the network there are several ways:

It can be connected to the Internet through a SIM card and WIFI .

Maintenance

Maintenance during long-term parking:

Store the remote controller in a dry and ventilated place, and reduce direct sunlight to prevent the battery from overheating. If it needs to be stored for more than three months, the recommended storage temperature range is 22 degrees Celsius to 28 degrees Celsius. Do not store the battery in places lower than minus 20 degrees Celsius or higher than 45 degrees Celsius.

Transport and storage

Caveat

To avoid possible injury and loss, the following items must be observed:

Since cables and small parts may be dangerous to children, be sure to keep children away from the parts of the remote control.

Note

1. Do not immerse the remote control in water. If it does, please wipe it with a soft dry cloth in time and turn off the power immediately.

2. It is forbidden to mechanically hit, crush or puncture the battery, and it is forbidden to drop the battery.

Smart APP

Log in

Click Register on the login page to enter the registration channel. The APP provides registration functions for plant protection teams and pilots. Users can fill in the necessary information and log in after successful registration.

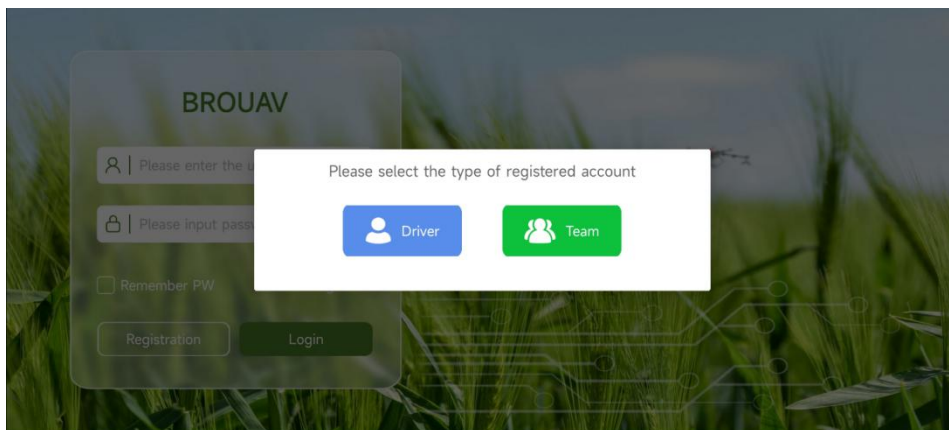

Picture.1

If you forget your password, you can click Forgot Password and enter your registered mobile phone number/email to retrieve it.

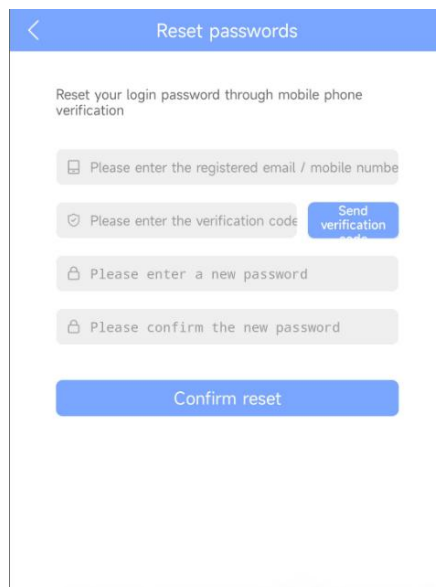

Picture.2

Mode selection

After logging in to the APP, you need to select the operation mode. It is divided into [spray mode](#) and [spreading mode](#).

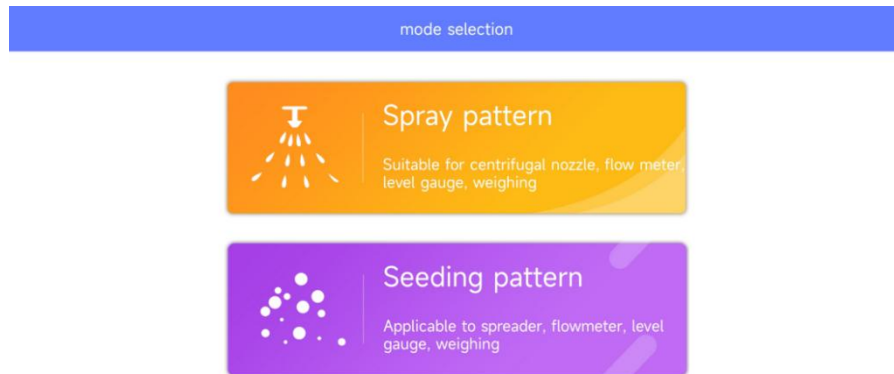

Picture.3

Type of connected device

After entering the corresponding operation mode, click the [unconnected](#) part of the main interface, the connection page will pop up, and the various devices are classified, mainly divided into four categories: UAV, RTK surveying and mapping, single-point surveying and mapping, and RTK equipment. Users can press Device connection needs to be selected. When connecting the drone, you need to select the connection method, and other devices can select the device type.

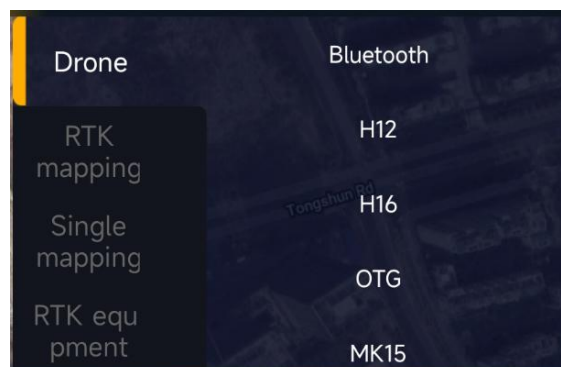

Picture.4

Interface introduction

The interface to connect the drone is as follows:

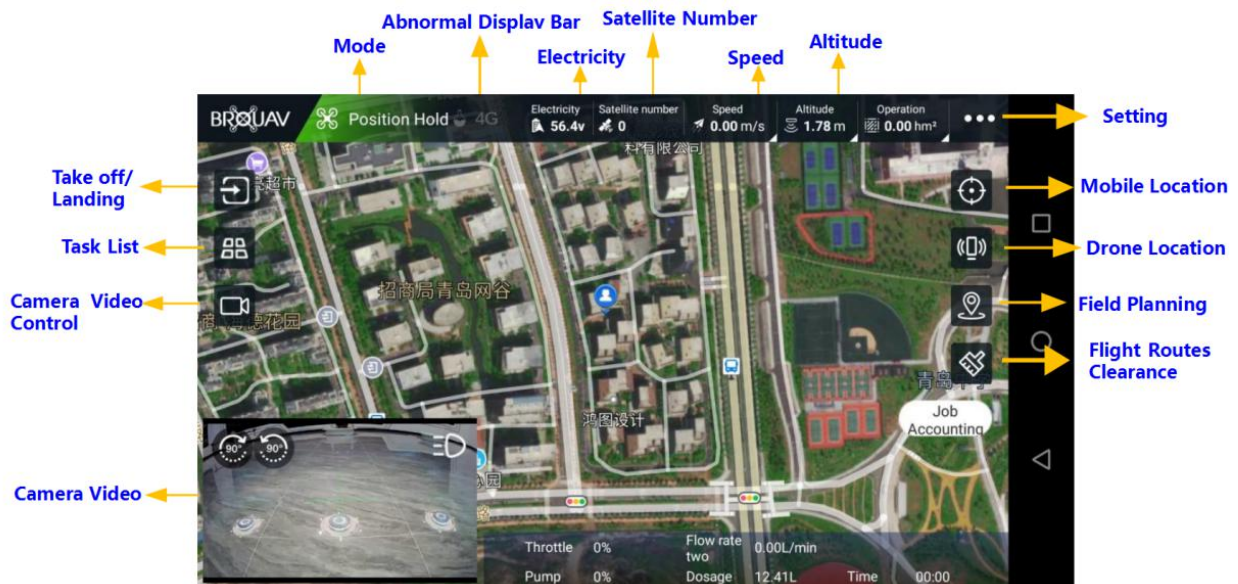

Picture.5

Figure 5 shows the display page after connecting the flight controller in spray mode. Swipe up or click on the auxiliary data display area to display the custom data display setting page. Users can open the data type to be displayed according to their own usage habits. 6 items are displayed. Click the Airplane Mode area in the upper left corner to pop up a disconnection prompt. Click the speed, radar height, and operation data area to set parameters such as AB point speed, mu consumption, centrifugal, turning mode, etc. If the user is using a smart battery, the power will be displayed as a percentage. Clicking the power percentage area will pop up a smart battery information display box.

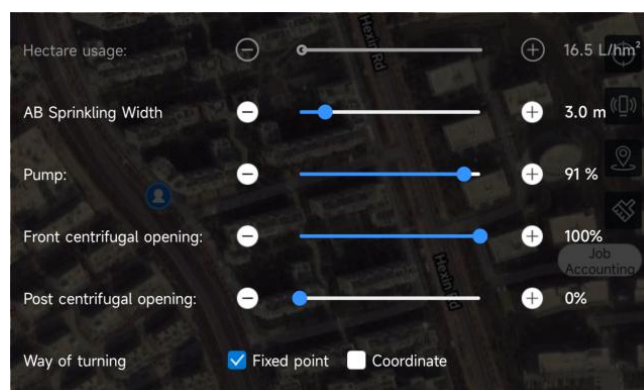

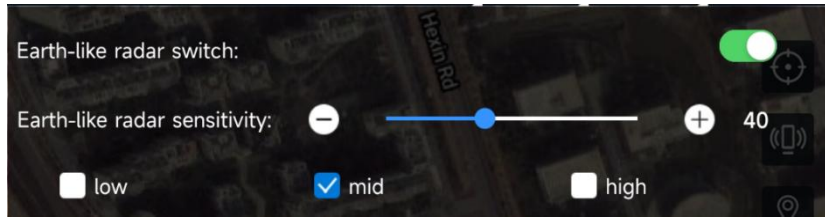

Picture.6

During the adjustment of the operation parameters, the **flow rate control** or **flow control** switch needs to be turned on on the setting page, and the mu usage parameters can be adjusted. Different operation modes have different adjustment ranges for the amount per mu; to adjust the opening of the pump, you need to turn off the **speed spray** function on the setting page.

Click the obstacle avoidance radar function button, and adjust the parameters in real time in the pop-up options. By setting the braking distance parameter, the user can set the distance between the obstacle avoidance braking and the obstacle after stopping according to the different weight and wheelbase of the aircraft, which further improves the safety of obstacle avoidance operations; obstacle or **front and rear obstacle avoidance** radar.

Click the video window switch button on the main page to quickly open or close the video window; at the same time, you can also click the video window area to switch between the map and the video window.

When the sensor and peripherals are abnormal, the corresponding fault icon will be displayed in the upper left corner of the interface. Turn on the contactor on the settings page to display the status of the open contactor. The following are the faulty sensor icons and explanations that may appear at the top of the main page:

As followed:

Accelerometer,Compass,Gyro,Vibration,Remote control,Liquid level,4G,Contactor

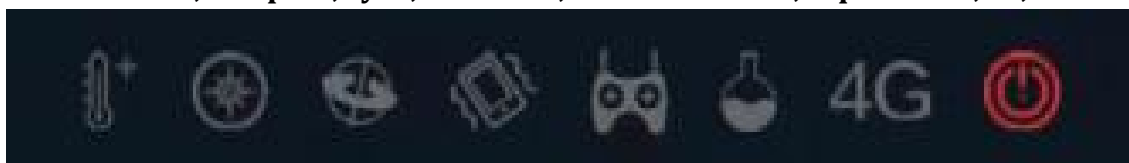

Picture.7

Mapping point

Click the Dotting button on the main interface, and select the corresponding surveying and mapping point method to enter the plot name input interface. The user can also cancel the input and directly enter the surveying and mapping point acquisition interface. If you choose to pick up points by plane, you must be in good condition of GPS positioning before you can enter the point check page.

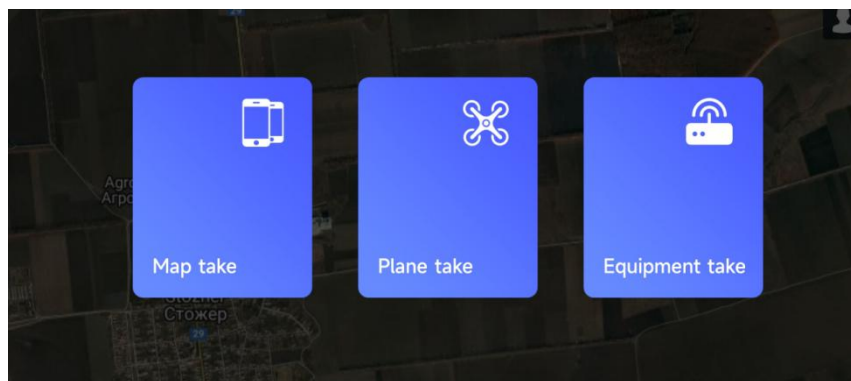

Picture.8

During the process of surveying and drawing points, different point types can be switched arbitrarily. The point type is divided into: [area point](#), [obstacle point](#), [waypoint](#). The obstacle area includes two types: polygonal obstacle area and circular obstacle area, and the type of obstacle area can be selected according to the needs. Currently, a maximum of [128](#) work area points are supported, a maximum of 10 obstacle area points are supported, and there is no limit to the number of obstacle areas.

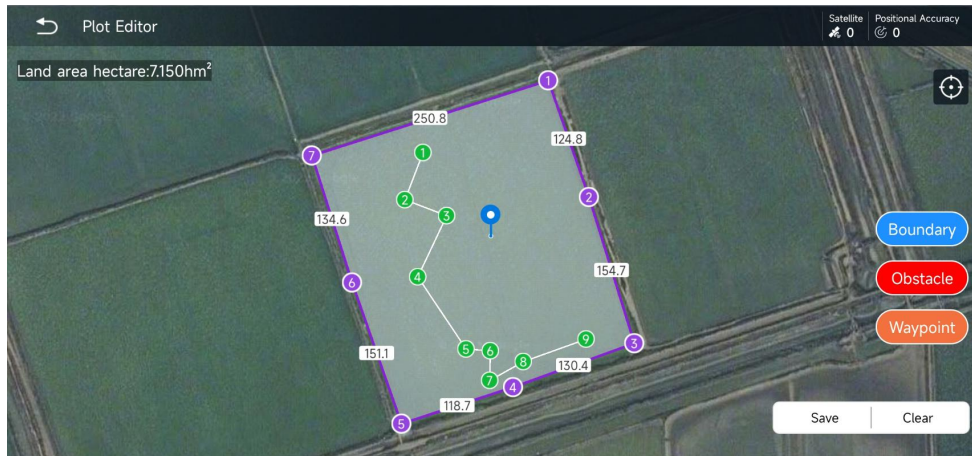

Picture.9

The barrier point exchange function can be adjusted for polygonal barrier areas. After selecting the obstacle area, click one of the obstacle points to be exchanged, and then select another exchange point in the pop-up window, and then exchange.



Picture.10

If you directly survey and map waypoints, you need to set the work area in advance and set the waypoints in the work area. When adding a waypoint, the **actual altitude** of the waypoint will be added at the same time. Users who use the fruit tree mode need to use the RTK mapping device to add the waypoint. The altitude of the waypoint is the altitude when the RTK device takes the point.

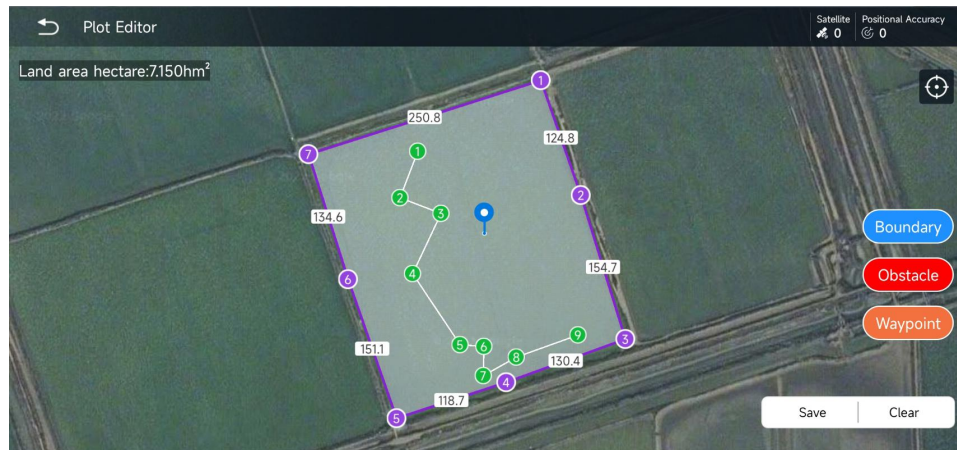

Picture.11

The altitude value can be changed, and the altitude of the waypoint takes effect only when the route planning is switched to fruit tree mode. Since there is a large error between the altitude data taken by non-RTK devices and the actual altitude, users who do not use RTK surveying and mapping devices and need to use the fruit tree mode should use it with caution. Users who use the fruit tree mode must ensure the accuracy of the waypoint altitude data to avoid dangerous operations; users who do not operate in the fruit tree mode do not need to pay attention to the waypoint altitude data.

Plot function

Plot sharing

Brouav provides users with two land plot directories, local and cloud. The land is preferentially saved to the local directory. Users can customize the upload to the cloud directory by clicking the upload button, and share it with all users under the same plant protection company. The content of the list is consistent with the management information of the web version of the land. At the same time, you can directly delete the plot files in the local directory. Swipe left on the file, and upload, edit, delete parcel buttons will appear.

The parcel sharing function can share the same parcel between different accounts. Switch to the cloud tab, click the share button, enter the account and mobile phone number of the pilot or plant protection team to be shared, and the plot can be shared. The shared person can see the plot in the cloud data under the current account:

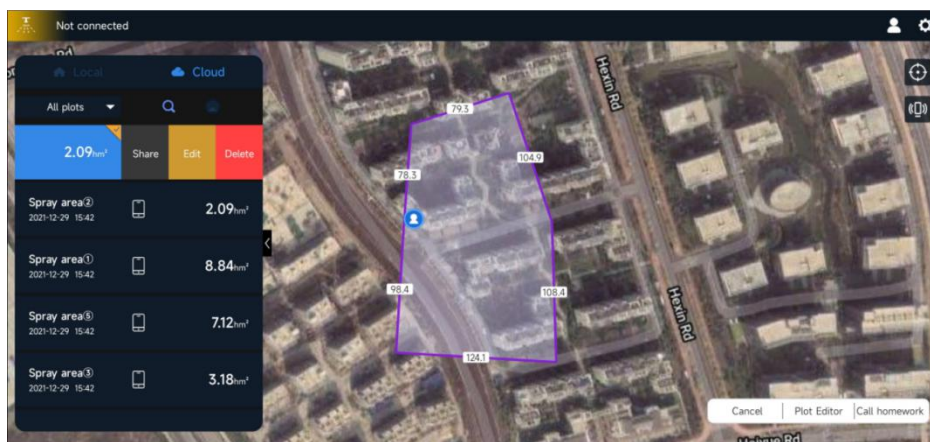

Picture.12

Nearby plots

The function of nearby plots needs to be switched to the cloud directory for use. After opening the cloud directory, click the blue state of the parcel sharing function button, indicating that parcel sharing is enabled, and the search range of parcels is the parcels uploaded to the cloud by all users; the gray state means that parcel sharing is disabled, and the search range will be

limited to The plot uploaded by this plant protection company. The search area for nearby parcels is a 5km radius circular area centered on the current device.

When in use, switch to nearby plots in the cloud directory, the system will automatically search and filter out the plots that meet the conditions, and display them in pages in the form of 5 plots on a single page, and you can view the current page on the map at the same time. There are 5 plots, the user can click on any displayed plot area on the map, and the system will automatically switch to this plot.

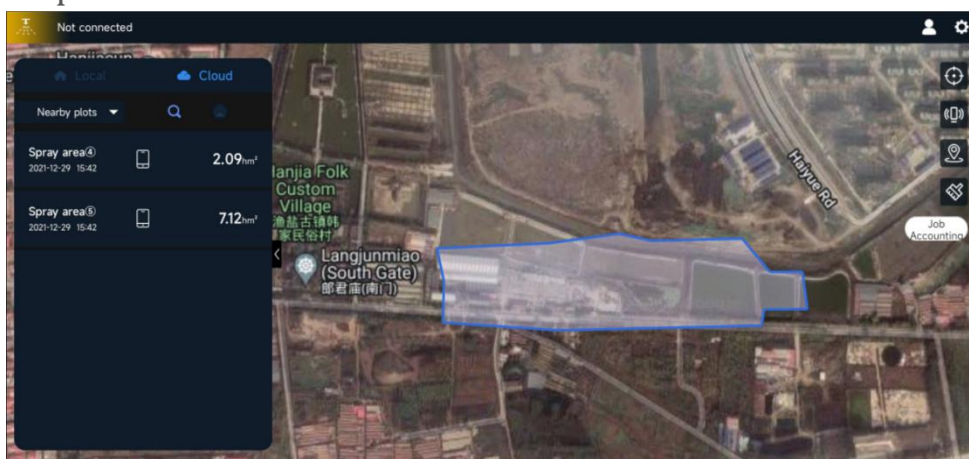

Picture.13

Plot preview

This function greatly facilitates users to find plots. Entering keywords in the search box can search and locate plots that meet the search conditions and display pictures. It supports fuzzy search and positioning:

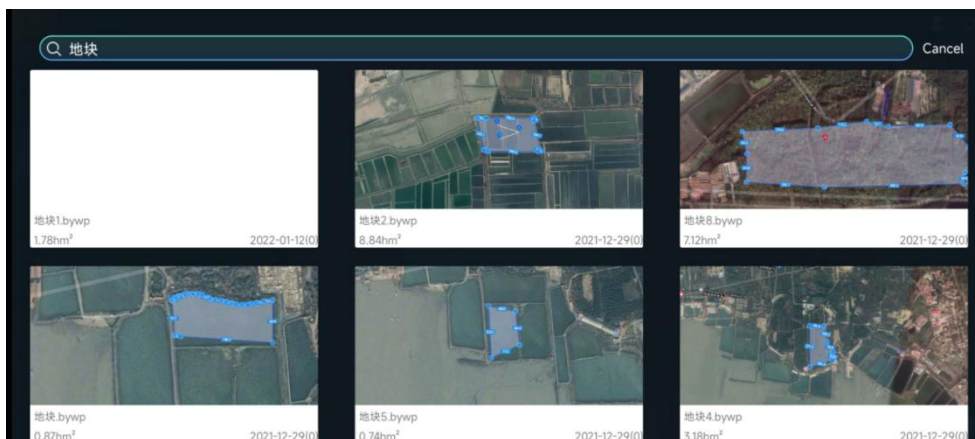

Picture.14

Plot Edit

After opening the plot list, click the plot editing button to enter the plot editing page, which is consistent with the surveying and mapping point page. You can add, delete, and move points in the work area and any obstacle area. The left side of the page is Obstacle area selection, the user can edit the specified obstacle area by selecting:

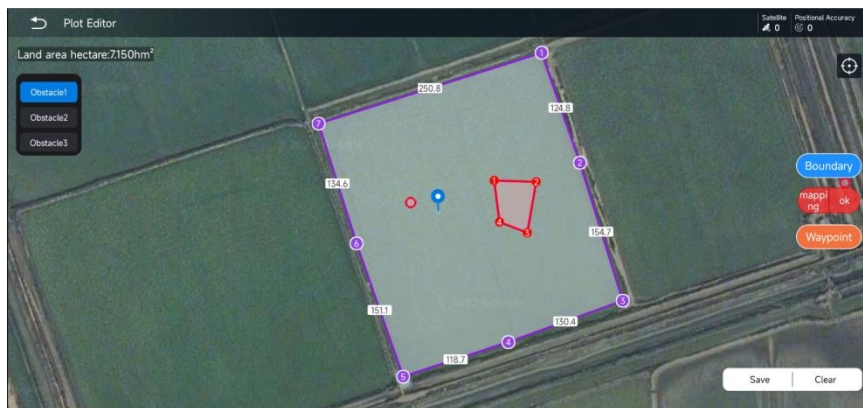

Picture.15

In the process of editing a plot, when you need to add a new area point between two area points, you can use the function of inserting area points. First select an area point, confirm the position of the area point to be inserted, and then click the Insert button to add a new area point before the selected area point, and update the area point synchronously without changing the already mapped area point. Number of all area points.

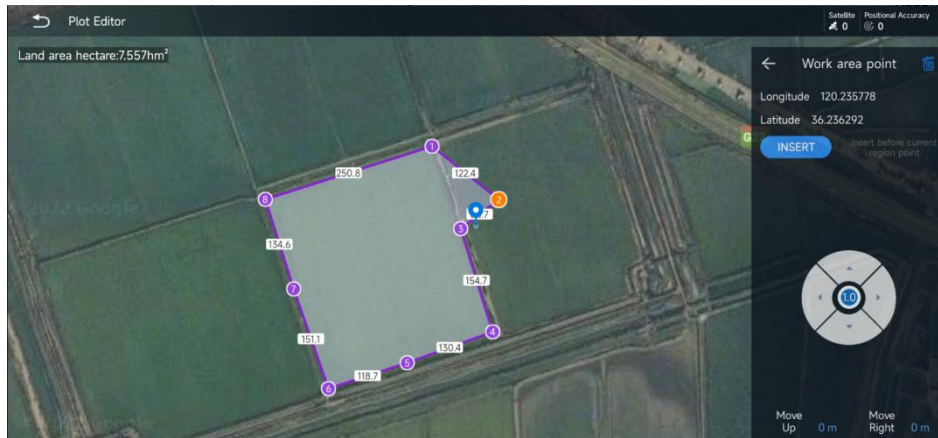

Picture.16

As shown in the figure above, select the area point 2, and choose the position of the insertion point.

After clicking Insert, a new area point will be inserted before the original 5 points, and the position of the previous survey point will not change, and the number will be automatically updated.

Route planning

Plot planning

Select any plot in the plot list, and click the call job button in the lower right corner to enter the route planning page, where **S** is the starting point and **E** is the ending point. As shown below:

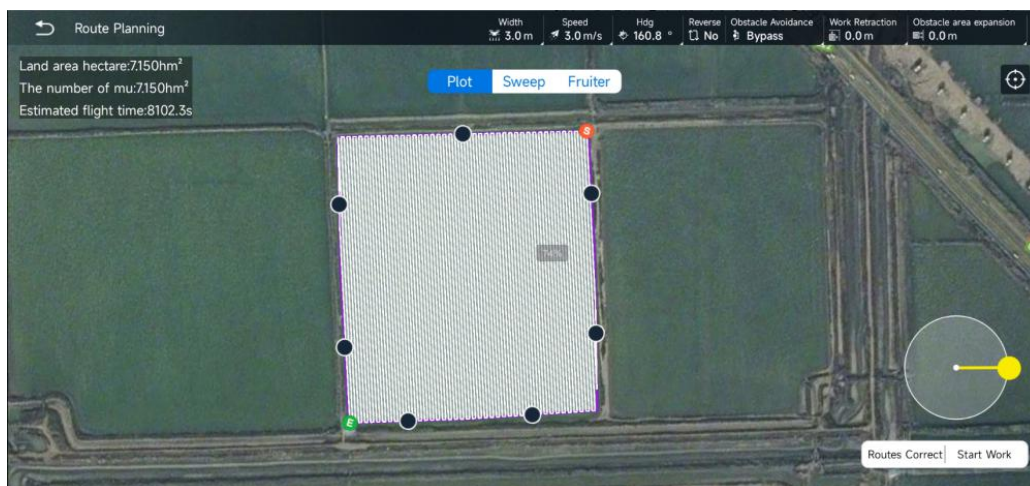

Picture.17

Confirm the heading angle: You can select a certain boundary, and the heading angle will be consistent with the selected boundary;

Confirm the starting point: when changing the starting point, you can click the reverse implementation above;

Reduction in working area/Outward expansion of obstacle area: Fine-tune the working area and obstacle area by selecting the inward contraction of the working area and the outward expansion of the obstacle area.

Route correction: Correcting the planned route can minimize the positioning error generated when mapping the plot, which is very convenient for users to operate. The usage method is: after the route planning is completed, place the aircraft in the calibration position, click the route correction, the entire area and route will be moved to the position based on the aircraft's positioning point as the first waypoint, and then click to start the operation and upload the route to the flight controller.

The route correction distance must not exceed 10 meters

When the local plot planning route is uploaded to the flight controller, the plot in the plot list will automatically become the plot for adding the route, and it will be automatically uploaded to the cloud. After re-planning and uploading, the old plot planning style will be overwritten by the new plan.

If you choose not to re-plan when re-calling the route, after entering the route planning page, except that you can change the flight speed, other planning parameters are invalid.

Sweep mode

After selecting the edge sweeping mode, you can set the number of laps of the sweeping flight operation. At the same time, you can also indent the sweeping route as a whole or unilaterally. You can also set parameters such as flight speed and spray width. The adjustment methods of all flight parameters are the same as Regular flight operations are the same. When entering the

sweep mode, the default heading is to point to the next waypoint.

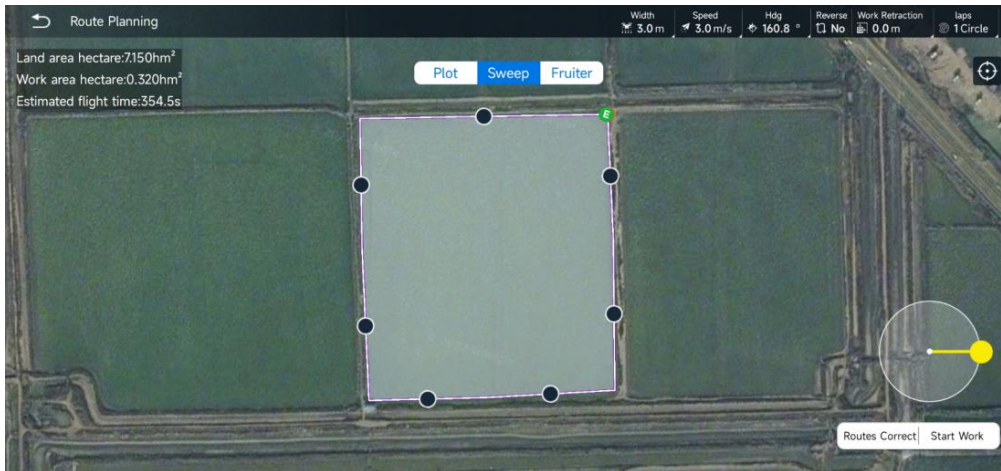

Picture.18

Fruit tree mode

Select the fruit tree waypoints and plots for surveying and mapping, call the job, cancel the re-planning, enter the route planning page and select the fruit tree mode.

Speed: The speed adjustment of the route in the fruit tree mode;

Height increment: In fruit tree mode, the distance from the altitude of all fruit tree waypoints to the actual working altitude, this parameter can be used to adjust the safe height of the aircraft from the crops during actual operation;

Waypoint action: The waypoint action can be set as hovering, spinning or circle, and the setting is enabled when the spraying method is selected as the waypoint mode; hovering can set the hovering spraying time; spinning and hovering can set the number of rotations; Hover can set the circle radius;

Spraying method: waypoint mode or route mode, the waypoint mode is only sprayed at the waypoint, and the route mode is the whole process;

Height change method: It can be set to slope or fixed point. The slope method is that the height changes synchronously with the position; the fixed point is that the height and the position change asynchronously and sequentially. Users need to flexibly choose the height change method according to the difference of the terrain to prevent accidents.

The following are several important parameter settings for fruit tree mode

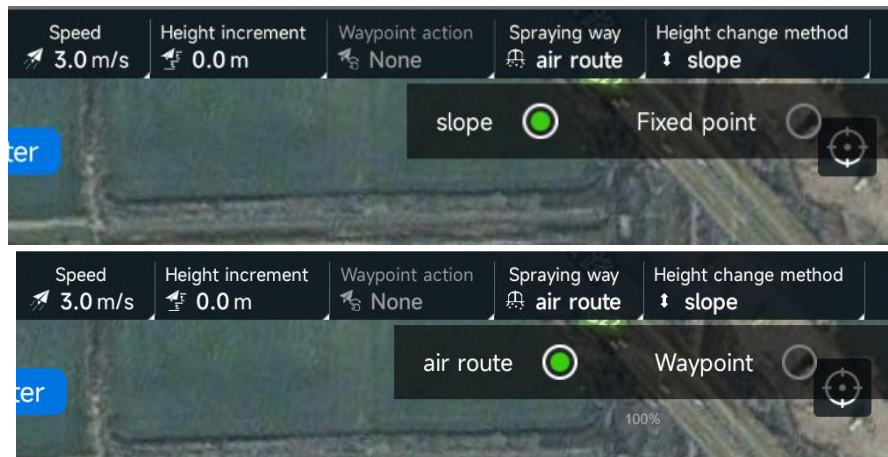

Picture.19

No matter which of the above operation modes, you need to click the start operation button after planning the route, confirm the start and end points of the work area, and upload the route to the flight controller.

APP settings

Agriculture settings

It is recommended that users adjust the parameters according to actual needs

Common settings: spray medium, return altitude increment, return speed, motor idle speed, execute action settings, manual obstacle avoidance, point to the next waypoint

AB point parameter setting: automatic line feed, manual AB point, AB-T

Position Hold Mode: Speed Limit, Speed Response, Brake Response

Autonomous operation: autonomous take-off altitude, autonomous route speed response coefficient

Flowmeter (spray mode): flowmeter measurement coefficient, flowmeter closed-loop control proportional coefficient, flowmeter closed-loop control integral coefficient, flowmeter protection switch, flow rate control, flowmeter quantity

Level gauge: level gauge protection switch, level protection action

Load cell: quality protection switch, quality protection setting value, flow control, overweight unlock check, overweight setting value, flowmeter

closed-loop control proportional coefficient, flowmeter closed-loop control integral coefficient

Pump parameter setting(spraying mode)/spreader(spreading mode): spraying at speed/spreading, line feed off pump/port 1, front and rear pumps/port 1-1, 1-2, port setting (AUX1-4), minimum Velocity/Flow, Maximum Velocity/Flow, Pump/Port 1 Delay On Time, Centrifuge/Port 2 Delay Off Time, Pump/Port 1 Speed Adjustment Range, Aircraft Speed Range.

Security Settings

Battery

Using the smart battery, the voltage and battery alarm thresholds set by the ground station are enabled at the same time, and the corresponding alarm actions are performed in the order of battery or voltage alarm triggering.

Calibration settings

Calibration settings include remote control calibration, accelerometer calibration, level correction, dynamic balance detection, flowmeter calibration, and weighing calibration.

Remote control calibration

In the remote control calibration interface, the user can select and change the operation mode (American hand / Japanese hand), and at the same time can set the flight mode of the 5-channel three-stage gear of the remote control, and supports 3 modes to choose from. Before calibrating the remote control, it is necessary to confirm the position and stroke of each channel. Generally, the stroke of 8 channels needs to be fixed at 1050-1950. Change the control mode (American hand / Japanese hand) through the APP, please confirm whether the firmware of the remote control supports the change before use.

Flowmeter Calibration

Enter the spray mode, click the reset button of the current data of the job statistics on the main page before calibration, reset the current dosage data to zero, fill the medicine box with medicine, and start spraying until all the medicine is sprayed, and then input the filling medicine the exact volume, click Calibrate to complete.

Weighing calibration

Click to tare before calibration, then place the weight on the load cell, input the actual weight of the calibrated weight, the unit is kg, and finally click to calibrate. When it is necessary to work, before adding the medium to the dosing box or barrel, it is necessary to click on the peeling to remove the quality of the container, and then refill the dosing medium to start the operation.

Flight

Operating environment requirements

1. Flight environment.
2. Keep away from the crowd!
3. The distance between the pilot and the drone is > 10 meters
4. Ground handling distance > 15 meters from drone
5. It is strictly forbidden to watch the crowd close to the drone within 100 meters!
6. Unmanned aerial vehicles take off and land, must be far away from high-voltage lines, transformers, steel structures, crowds, roads, etc.

Flight restrictions and no-fly zones

1. Sensitive area

The station of troops, the station of special agencies, nuclear power plants, border lines, political center areas, military exercise areas, etc. all belong to the national security level

The sensitive area itself has relatively high requirements for security and confidentiality. From a safety and legal point of view, we must avoid working in sensitive areas and avoid safety accidents.

2. No-fly zone

The airport is a sensitive area where civil airliners frequently take off and land. The emergence of unmanned aerial vehicles can cause flight delays and can cause personnel accidents.

According to the laws and regulations of relevant organizations, whether domestic or foreign, drones must fly in the prescribed airspace. According to the relevant regulations of the headroom, 10 kilometers on both sides of the runway extension direction and 20 kilometers at both ends of the runway are used as the headroom of the headroom, flight is prohibited.

Pre-flight inspection

Aircraft inspection and operation

The following should be noted:

1. Long-term idle or transfer place is far away, the aircraft should be calibrated with magnetic compass to avoid abnormalities.
2. Confirm the rocker mode before take-off to avoid wrong rocker mode;
3. Make sure that the remote control and the battery are fully charged before take-off, to avoid the remote control battery being too low and losing control;
4. Confirm that both the arm and propeller are deployed before take-off. The more careful the pre-flight check, the lower the probability of problems.



Qingdao Zhongfei Intelligent Technology Co.,Ltd

Address: No. 66, Huazhong Road, High Tech District, Qingdao, Shandong

Tel: +86-532-68076300

Fax: +86-532-68076301

E-mail: Sales@brouav.com